

PATIO DOORS

SERIES 7000



Craftsmanship. Style. Performance.

Strassburger
SINCE 1949
WINDOWS AND DOORS

Designed To Work Like A Charm

All Strassburger patio doors have a common characteristic ... quality craftsmanship that translates into performance that's built to last



- It's always smooth and quiet sliding from the sturdy, patented dual-tandem wheels on these doors. (They've withstood, without failure, 119,000 test cycles carrying a 165 lb. sash - the equivalent of over 30 years of constant use!). Not to mention that wheels now include sealed bearings for even longer life.

- Try the fingertip test: bet you can open this door with just the tip of a finger! The easiest door to operate in its category.
- Our lock has retractable latches so they will not break if the door is shut with them in a closed position.
- Take the monorail - the sturdy all-aluminum angle-legged tracks on these doors ensure stability and ease of use.

- It's smooth sliding all the way with the screen doors. Their patented spring-loaded rollers are fully adjustable at each corner, to prevent bothersome derailing.
- Installer-friendly design means uneven surfaces are never a problem - it's a snap to plumb and square Strassburger doors.





It's All A Matter Of Style

Great looking patio doors that are more energy-efficient than ever and add extra value to your home

Whether you are building a new home or purchasing replacement patio doors, Strassburger Windows and Doors offers a wide range of styles that make them the ideal choice for your home's design.



The most innovative and popular patio door systems. A hallmark of quality living.

The Strassburger patio door series is often imitated but never duplicated. It opens up the future to a new generation of premium-quality all PVC doors with a host of outstanding features and benefits. Available in either a mechanically fastened (7800 Series) or welded (7500 Series) sash design. Standard colours are solid white or beige, or choose from a variety of outstanding custom colours.

The perfect combination of beauty and practicality

Doublenature® Stained Vinyl patio doors (7500 Series) add a natural elegance to your home's exterior and a rich, warm complement to the interior. Choose from four exquisite factory applied stains that work well with any home's palette and are easy to maintain.

PVC patio door performance paired with the natural splendour of wood

Craftsman Series interior wood patio doors (7800 Series) combine the natural beauty of hand-crafted solid wood interior moldings with the total performance of PVC. The warmth and elegance of interior wood can be combined with a variety of standard or custom exterior colours to perfectly integrate your doors with your architecture.

Opens any way you like

Available in 2-panel, 3-panel and 4-panel configurations with a wide range of energy-efficient glazing options, decorative grilles and sizes. Standard 2-panel patio doors are available in 5', 6' and 8' widths with two height options. Custom sizes are also available upon request.

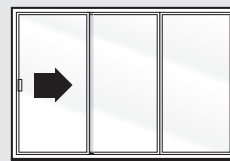
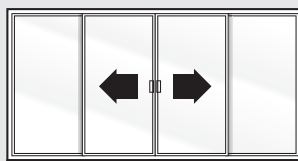
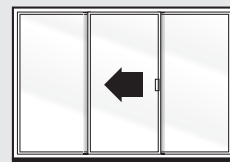
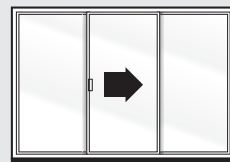
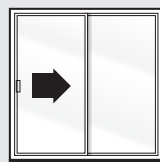
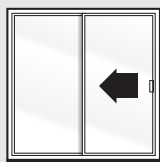



Beautifully Innovative

Performance and durability designed to fit your lifestyle.

The remarkable performance of Strassburger patio doors is a result of attention to the smallest of details in the quest for premium product quality.

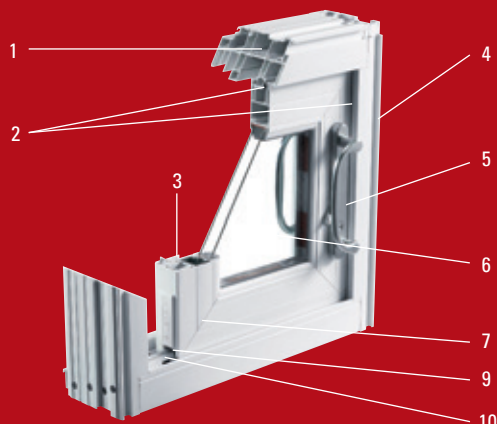

7500 Series Welded Sash

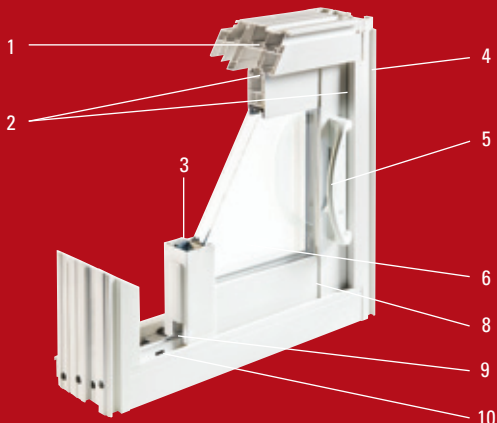

7800 Series Mechanical Sash

- 1 Energy-efficient multi-chamber design
- 2 Triple weather stripping virtually eliminates air infiltration
- 3 Meeting and mobile stiles steel reinforced
- 4 Integrated drywall retainer
- 5 Standard or multi-point locking systems
- 6 Accommodates 1" triple-glazing or blinds
- 7 Fusion welded sash design
- 8 Mechanical sash design
- 9 Patented sliding system
- 10 Exclusive patented water drainage system incorporated into the lower sill

Performance - Test Results

	Air	Water	Wind	Forced Entry
7500/7800 Series	A3	B4	C3	F2
Ind. Standard	A1	B1	C1	F1



7500 Series White PVC

These doors are made with components that are built to stand the test of time. You'll enjoy a "hassle-free" door system with performance, durability and elegance guaranteed for years of regular use. Both door styles are ideal for the variable Canadian climate, are NAFS compliant and meet EnergyStar® requirements.

- Multichamber profiles and multiple weatherstripping help eliminate most outside noise
- Strassburger PVC patio doors, with their exceptional insulation, are among the most energy-efficient on the market
- 100% PVC extrusions are designed to provide superior resistance to severe weather conditions
- Easy to open and close, dual-tandem nylon wheels offer a smooth and quiet operation
- Optional multi-point locking system provides heavy-duty security
- Lower sill design provides safer entry and exit
- Designed to be aesthetically and structurally compatible with other Strassburger window styles
- Operating hardware is available in several options, colours and finishes
- Standard extrusion colours are solid white and beige. See colour chart for exterior standard and custom colours

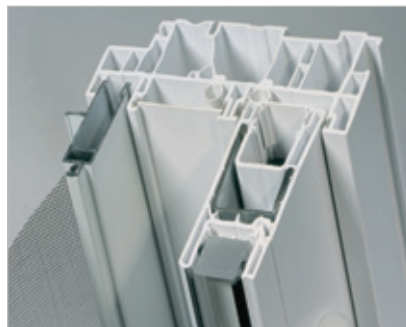

Superior stability

Galvanized steel reinforced panels ensure rigidity and stable operation



Increased protection

Fixed and mobile panel rails meet and interlock perfectly, making door removal from the outside almost impossible.





Doublenature® Patio Doors

The advantages of PVC. The appearance of wood.

Strassburger Doublenature® patio doors match the aesthetic appeal of wood with the unmatched performance of PVC.

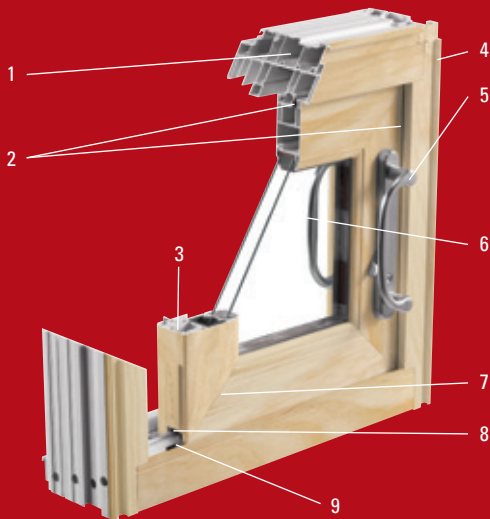

7500 Series Welded Sash

- 1 Energy-efficient multi-chamber design
- 2 Triple weather stripping virtually eliminates air infiltration
- 3 Meeting and mobile stiles steel reinforced
- 4 Integrated drywall retainer
- 5 Standard or multi-point locking systems
- 6 Accommodates 1" triple-glazing or blinds
- 7 Fusion welded sash design
- 8 Patented sliding system
- 9 Exclusive patented water drainage system incorporated into the lower sill



7500 Series with Doublenature® finish

Doublenature® provides a range of inspiring looks that add beauty and a feeling of cosy comfort to your project, whether it's large or small, doors or windows. Doublenature® offers the organic and natural warmth of wood... without maintenance. At once trendy and timeless, the natural wood finish of the Doublenature® collection blends with other materials and textures to give your project its own unique look.

With a finish that can be applied inside as well as outside, Doublenature® products provide the most realistic wood finish in the PVC industry. It's the perfect combination of beauty and practicality, innovation and tradition.

- Optional multi-point locking system provides heavy-duty security
- Fixed and mobile panel rails meet and interlock perfectly, making removal from outside almost impossible
- Lower sill design provides safer entry and exit
- Designed to be aesthetically and structurally compatible with other Strassburger window styles
- Operating hardware is available in several options, colours and finishes
- Standard extrusion colours are solid white and beige. See colour chart for exterior standard and custom colours

Performance - Test Results

	Air	Water	Wind	Forced Entry
7500 Series	A3	B4	C3	F2
Ind. Standard	A1	B1	C1	F1

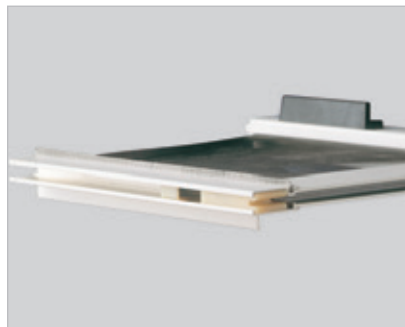

Sturdy screen

Extruded screen with stainless steel screws and patented adjustable spring-loaded suspension system in each corner are designed not to derail or jam.



Water-based, UV-resistant stain

Doublenature® is available in a range of natural colours inspired by some of the world's most noble wood species: oak, pecan gold, mahogany and walnut.





Carpenter Quality, Maintenance Free

The warmth of real wood for a classier, more upscale look

Solid wood interior moldings are the patio door option that enhances your regular PVC doors.

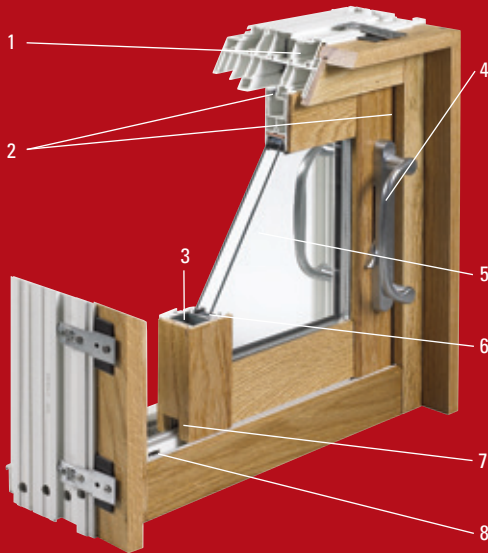

7800 Series Mechanical Sash

- 1 Energy-efficient multi-chamber design
- 2 Triple weather stripping virtually eliminates air infiltration
- 3 Meeting and mobile stiles steel reinforced
- 4 Standard or multi-point locking systems
- 5 Accommodates 1" triple-glazing
- 6 Efficient division between the glass and steel reinforcement
- 7 Patented sliding system
- 8 Exclusive patented water drainage system incorporated into the lower sill



7800 Craftsman Series Interior Wood

Patio doors with solid wood interior moldings provide the same superior protection whatever the rigours of the elements. Watertight, insulated and solid, this style is ideal for the variable Canadian climate, is NAFS compliant and meets EnergyStar® requirements.

- Available in oak or pine to complement your interior cabinetry or decor
- Wood remains protected from the elements, even when the patio door is opened for ventilation
- No contact between glass and wood, reducing the risk of premature wood aging

Other technical features of 7800 series patio doors include:

- Optional multi-point locking system provides heavy-duty security
- Fixed and mobile panel rails meet and interlock perfectly, making removal from outside almost impossible.
- Lower sill design provides safer entry and exit
- Designed to be aesthetically and structurally compatible with other Strassburger window styles
- Operating hardware is available in several options, colours and finishes
- Standard extrusion colours are solid white and beige

Performance - Test Results

	Air	Water	Wind	Forced Entry
7800 Series	A3	B4	C3	F2
Ind. Standard	A1	B1	C1	F1



The warmth of real wood

90° assembly system gives the patio door a genuine wood look



Handle

Choice of luxury metal finish handles





It's All In The Details

Our attention to detail doesn't stop at the patio doors... it's the finishing touches that make a Strassburger door complete



This patio door perfectly complements our high-end window profiles for a spectacular look

Choose from a variety of patterns to create a spectacular door style that complements your architecture and your individual taste.

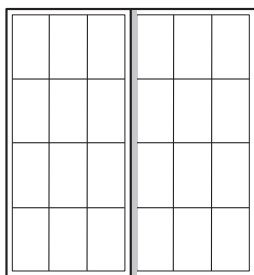

Colonial

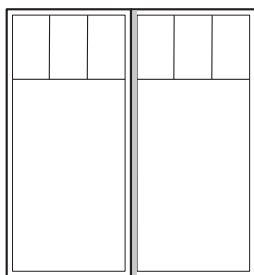

Ladder

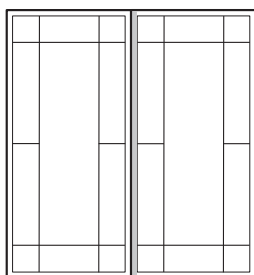

Prairie



Brickmould and trim options

A wide variety of decorative brickmoulds, jamb extensions and trim options are available to finish the patio door. Most brickmoulds have tear-out systems to allow for siding. Available in standard white or beige, these extrusions can be painted to match your chosen door frame colour.



Grille designs complement your architectural style

Grilles placed within the airspace between the insulating glass create a sleek, traditional look that is easy to clean. We offer a wide selection of grille styles and colours that will enhance the look of your doors and complement the design of the building.

Multiple shapes, sizes and colours* of grilles to choose from. Exact colour matches to grilles are not always possible. Default grilles are pewter or an SDL grille.

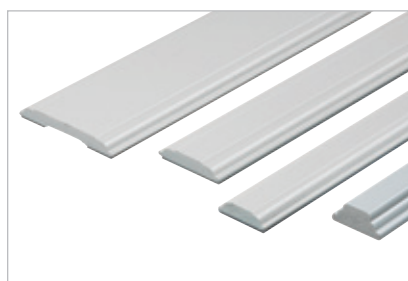

Simulated Divided Lites

Surface-mounted grille bars create a unique and distinctive multi-pane effect known as simulated divided lites.



Foot lock

Convenient and easy-to-use tamper-proof foot lock provides additional security



Standard 1/2 Screen

Standard smooth sliding 1/2 width screen is equipped with patented spring-loaded rollers, fully adjustable at each corner



Hide-Away Screen

Optional Hide-away screen is a unique design that allows the screen to retract and be virtually out of sight when not in use



Blinds

Integrated aluminum mini-blinds, for maintenance-free privacy



New technology turns glass into insulation

Strassburger patio doors are glazed with cutting edge technology from Cardinal Glass Industries. Through research and engineering Cardinal glass adds new standards of comfort, energy savings and value to your home. Cardinal glass is specifically designed to let clear light stream into your home while rejecting the sun's heat and damaging UV rays that shorten the life of drapes and furniture. All Cardinal units come complete with the XL Edge spacer system which provides proven thermal and structural performance.

LoE-i89 delivers triple-pane performance in a double pane window when used in combination with other LoE glass

- remarkably low U-factors
- reflects escaping heat back into room
- high energy efficiency

LoE-180 is the ideal glass for passive solar applications

- high solar gain
- blocks interior heat loss to outside
- dramatic comfort improvements

LoE²-272 provides year round comfort

- reflects heat back into room on cold days
- promotes easier control and maintenance of interior air
- reflects harmful UV rays

LoE³-366 reflects the sun's heat without affecting the view

- provides premium insulation and comfort
- rejects 95% of sun's damaging UV rays
- highest levels of energy savings

Neat™ windows almost clean themselves

- the sun's UV rays loosen the dirt so rain water can wash it off
- ultra smooth glass disperses water
- windows stay cleaner longer

Preserve™ protects your glass from getting scratched or damaged in shipping, handling and on the construction site

- factory applied protective film
- saves time, money and jobsite hassles
- simply peels off



White Black Oil Rubbed Bronze



Brushed Antique Chrome Brushed Nickel Coppertone

Hardware Options

The slim design and superior quality of all the door hardware ensures your patio doors and screens perform flawlessly for years. Contoured shaped metal handles are offered with exterior/interior grip. All of our standard locking mechanisms are anti-slam and encased in galvanized steel reinforcement. A multi-point locking system (optional) provides optimum security and resistance to forced entry.



Double and triple glazed windows deliver outstanding thermal performance. Low conductivity warm edge spacers keep the panes of glass apart.



Standard or custom. You pick the colour

You've chosen the right patio door to make your home just the way you want it, now it's time to pick that perfect colour. We offer 50 standard colours chosen specifically to complement any new home design or retro-fit. Custom colour matching is also available.

These finishes are formulated to look better, last longer and are applied by our own specialists in a controlled, dust-free environment. We take care to use only water soluble paint so clean-up and disposal is efficient and doesn't affect the environment.

*Colour disclaimer: We cannot guarantee that the colours shown in the product images are exactly correct to the product. Please consult your Strassburger Windows and Doors dealer for exact product and colour chip matches.



The Energy Plus company since 1949

Proudly Canadian, we're dedicated to designing and building energy-efficient products

Strassburger Energy Star® energy-efficient windows and patio doors deliver year-round comfort and reduce, if not eliminate, condensation during colder weather. All Strassburger windows come with many glazing options to suit your needs and the region you live in.

To qualify for the Energy Star® mark, windows and patio doors must meet strict technical requirements for thermal performance. They must qualify based on either their U-value (rate of heat transfer from a warm area to a cold area) or their Energy Rating (a scale that takes into account a product's U-value, potential solar gain and air tightness). To ensure the integrity of the Energy Star® mark, all product testing is done by accredited laboratories under standardized, quality-controlled conditions. Visit our website to review all the Energy Star® and NFRC ratings on all our products.

The best windows, backed by the best warranty

We promise to adhere to the highest standards of honesty and integrity in all our relationships with customers, suppliers, prospects and employees and at all times provide high-quality products and service.



For information on other outstanding fenestration products offered by Strassburger Windows and Doors visit: www.strassburger.net

Talk to your dealer about a visit to the Kitchener or Barrie showrooms to see our complete line of windows and doors.



Cardinal Glass Industries



Dealer stamp



www.strassburger.net